



17801



Basic 10M-25M Firing Range (Zero)

RANGE DESIGN GUIDE



RANGE AND TRAINING LAND PROGRAM – MANDATORY CENTER OF EXPERTISE

U.S. ARMY ENGINEERING AND SUPPORT CENTER, HUNTSVILLE

HUNTSVILLE, ALABAMA

256-895-1534

[EMAIL RTLP](#)

General

This document contains information specific to a Basic 10M-25M Firing Range (Zero). The document includes references to sections of the RDG for information that is general to multiple range types. The document describes the design and construction information that is specific to the range and is not contained in, or differs from, the general section. Use both the specific information in this section and the general sections referenced together for a complete, useable range.

Purpose

This range is designed for training shot-grouping and zeroing exercise with rifles and squad automatic machine guns. This range is used to train individual Soldiers on the skills necessary to align the sights and practice basic marksmanship techniques against stationary targets. This range requires no automation but can support other live-fire training (i.e., alternate pistol qualification, advanced rifle marksmanship, and shotgun qualification).

Primary Features

This section provides the standard layout and a listing of the primary features that are standard on a Zero; separated into Range and the Range Operations and Control Area (ROCA). The tables include the number and/or size of each item included in a standard facility with hyperlinks to the RDG section with the general design and construction requirements.

Standard Layout

The following drawings depict the standard layout for the range. They are included at the end of this document.

- [25Z-C-01 25M Zero](#)

Range

NUMBER	FEATURE	RDG SECTION
	Target Boots	Target Boots
	1-Man Fighting Position	
	Range Signage	Range Signage

ROCA

NAME	SIZE	UoM	RDG SECTION
Control Tower – Small Arms	1	EA	Range Control Towers
Latrine: Vault (Latrine: Water)	330 (550)	SF	Latrines
Bleacher Enclosure	1	EA	Bleacher Enclosure
Covered Mess	800	SF	Covered Mess

Ammunition Breakdown Building	185	SF	Ammunition Breakdown Building
-------------------------------	-----	----	---

Design

Use the standard Zero Range layout referenced above as the basis for the range.

The standard Zero includes 32, 4-Meter wide lanes. Each lane includes boots for a target frame at both 10 and 25 meters. Each lane has a foxhole and prone firing position at the firing line.

General Range Design Requirements

This section contains references to the general range design sections of the RDG. Use these in addition to the sections for a specific item or structure and the design requirements in this document specific to the Zero.

General

- [Fire Protection](#)
- [LEED](#)
- [EPACT](#)
- [Furniture](#)
- [ADA](#)
- [Utility Services](#)

Civil Range Design

- [Siting Considerations](#)
- [Roads/Trails/Parking](#)
- [Line of sight](#)
- [Topographic Surveying](#)
- [Surface Danger Zones](#)

Electrical Range Design

None required

ROCA

Refer to the [ROCA-General](#) section of the RDG for general design information. The ROCA for the Zero Range is based on the standard Small Arms ROCA, but without the Operations/Storage or Classroom buildings.

Firing Line

Each lane has a foxhole and prone firing position at the firing line.

Down Range

Though Zero Ranges historically have backstop berms, the berms are not required. Backstop berms help contain spent rounds which can help reduce environmental impacts. Because they are not required for the operation of the range, they are typically installation (O&M) not MILCON funded.

Line of sight

Refer to the [Line of Sight](#) (LoS) section of the RDG for LoS requirements, procedures and submittal requirements.

The Zero range is flat with only minimal slope to drain.

Targetry

The Zero Range uses paper targets with no automation.

Requirement Documents

Refer to Training Circular TC 25-8, Training Ranges, for additional information and references to the FMs, ARTEPs, TCs, etc. that describe and require the training on this type of range. The latest TC 25-8 is available at Army Knowledge Online (www.us.army.mil) and the General Dennis J. Reimer Training and Doctrine Digital Library (www.train.army.mil).

Additional Information

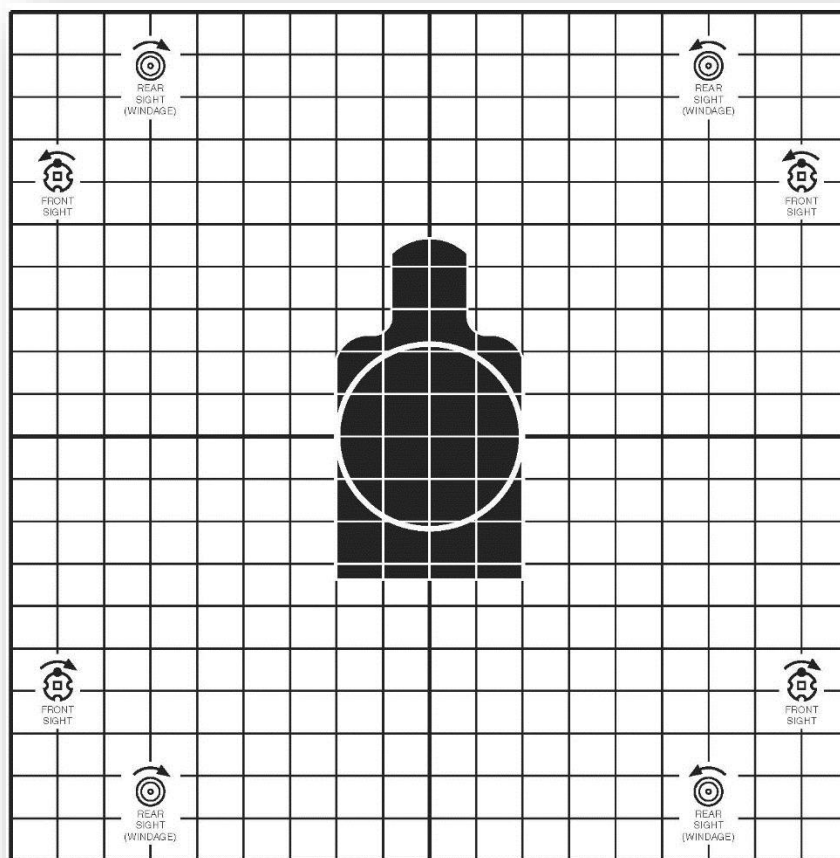

TYPICAL ZERO TARGET

Rev.	Date	Description

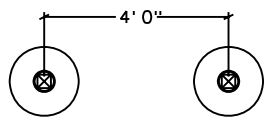
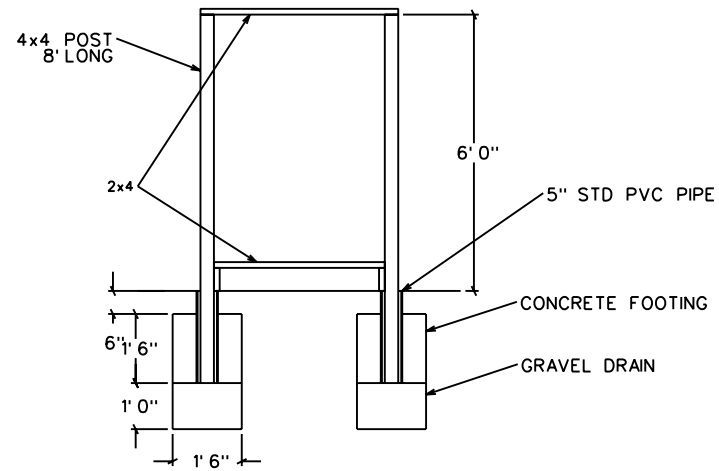

TARGET BOOT DETAIL

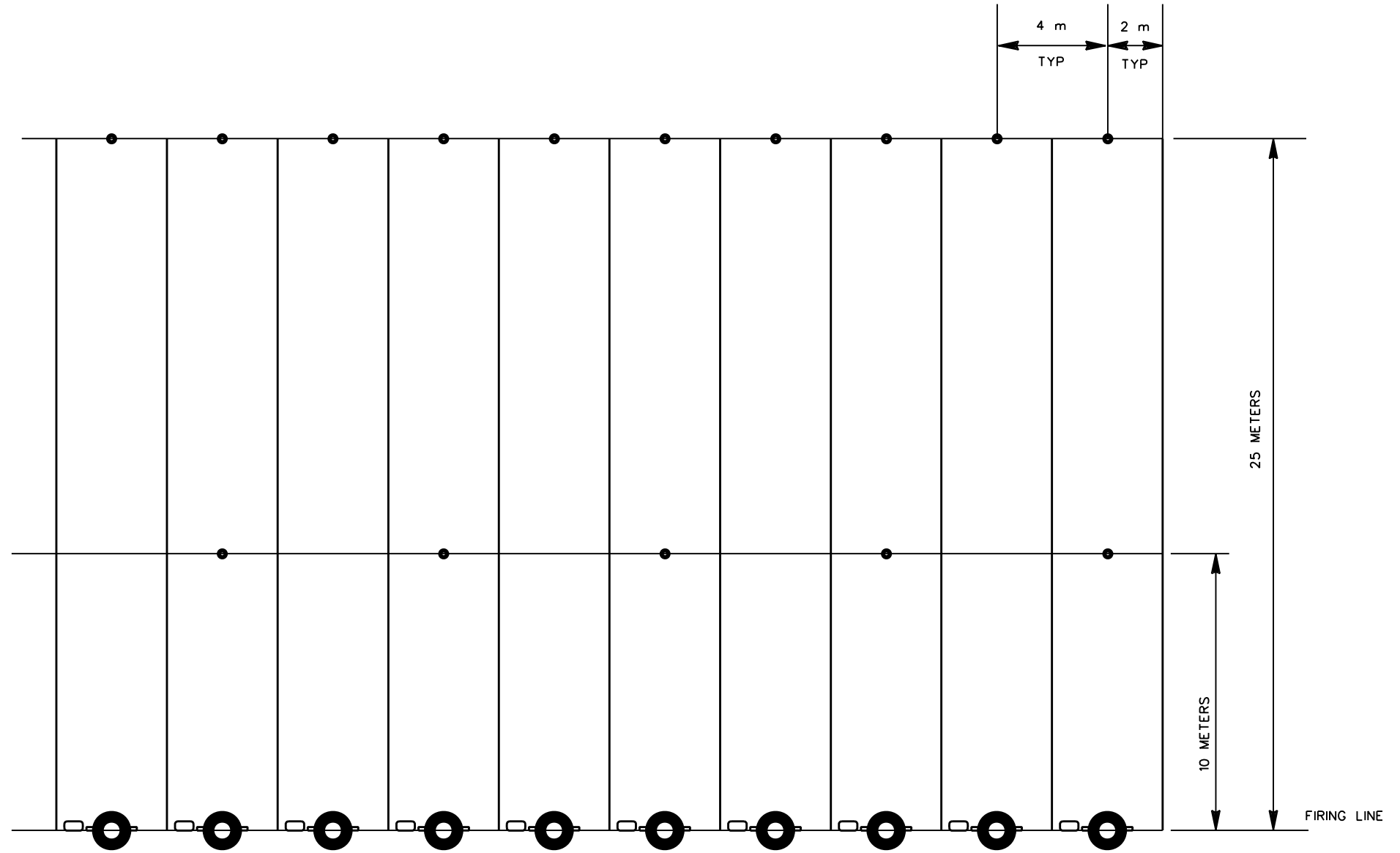

LEGEND

- FOXHOLE FIRING POINT
- V-NOTCH RIFLE RESTING PEG
- SANDBAGS
- TARGET BOOT

NOTES:

10 LANES SHOWN OF 32 LANE RANGE

FIRING POINT AND TARGET ARE ON A FLAT PLANE +/- 1°

Designed by:	Date:	Rev.:
Drawn by:	Design file no.:	
Reviewed by:	Drawn scale:	
Submitted by:	File name:	
	Plot date:	
	Plot scale:	
U. S. ARMY ENGINEERING AND SUPPORT CENTER, HUNTSVILLE, ALABAMA		
15 APR 2005		

RANGE AND TRAINING LAND PROGRAM	FCC-17801
STANDARD DESIGN MANUAL	25 M ZERO RANGE